

City of Indianapolis Geographic Information Systems (GIS)

Digital Data Submissions Standards



Table of Contents

I.	Introduction.....	1
II.	Definitions and Terms	1
III.	Captured Assets and Features	4
IV.	Public Projects (DPW Capital Improvements): Digital Data Submission Process.....	4
V.	Private Projects: Digital Data Submission Process.....	6
VI.	Contents of the Digital Data Submission.....	7
VII.	Record Drawing Submittal File Requirements	7
	Appendix A: Graphic File Features	14
	Appendix B: DDSS Submission Checklist	16
	Appendix C: Attribute Table Definitions and Descriptions.....	19
	Revision History	24

I. Introduction

Please read this complete document carefully prior to entering or submitting any data.

The City of Indianapolis (hereinafter referred to as City) has adopted geographic information system (GIS) technologies to store, manage and maintain geographic/spatially related data. One of the most important methods of collecting this data is through the Digital Data Submission.

Publicly available GIS information for Indianapolis can be accessed from <http://data.indy.gov/>

Disclaimer: The City of Indianapolis data is not warranted for accuracy or merchantability. Use of released data is appropriate only for preliminary engineering and corridor layout studies.

II. Definitions and Terms

.dwg – Autodesk AutoCAD Version 2013 or better - Primary

.dxf – Universal Drawing File Exchange Format

BMP: Best Management Practice can refer to a structural stormwater management or non-structural stormwater measure (e.g., restrictive zoning, reduced impervious areas, etc.). BMPs are designed for the benefit of water quality and quantity control.

Contractor (Public Projects): The person, firm or corporation with whom the OWNER has entered into the Agreement to perform the Work.

Construction Digital Plan Data: Drawing files (.dwg or .dxf) representing all applicable items from Storm Features and Miscellaneous Features.

Construction Plans: Plans that are created and prepared for bidding or quoting the construction of a project. These plans shall be the same plans used for permitting.

DBNS: The City of Indianapolis Department of Business and Neighborhood Services.

Design Consultant: The firm contracted by Professional Services Agreement with DPW for the design of a public project or contracted with the developer for the design of a private project.

Developer: Company applying for or maintaining a Drainage Permit through DBNS to develop or redevelop on private property.

DPW: The City of Indianapolis Department of Public Works.

DPW Project Manager: Department of Public Works (DPW) Lead Project Manager responsible to provide items listed in the Professional Service Agreement to be supplied by DPW, for public projects.

*City of Indianapolis GIS
Digital Data Standards, Last Edited: 9/30/2024*

Final Completion Date (Public Projects): The completion of all Work required by the Contract Documents, including all punch list items and the delivery of all closeout documents to OWNER.

Final Construction Records (FCR) Folder: The folder for a Public Project housing all final records, including but not limited to the Record Reproducible Plans, Digital GIS Data, Digital Plan Data, Digital Data Attribute Tables, Easement/ROW Documents, Certificate of Substantial Completion, Final Change Order Summary Sheet, Final Change order, Form IC 642, etc.

GIS Data Support Staff: DPW Staff responsible for reviewing Digital Data Submittals for DPW Public Projects.

IndyGIS: GIS Division of Indianapolis/Marion County Information Services Agency (ISA).

Inspection Consultant (DPW) or Inspecting Project Representative (IPR) (DBNS): Firm contracted by Professional Services Agreement with the City for the inspection of a private project.

ISA: The Indianapolis/Marion County Information Services Agency.

Owner (Public Projects): The City of Indianapolis, Indiana, acting by and through the agency or Department designated in the Agreement or other documents issued in solicitation of Bids; and such term shall also include the Project Manager or other duly appointed representative of such agency or Department but shall not include ENGINEER.

Owner (Private Projects): Owner, applied to a building or land, shall include any part owner, joint owner, tenant in common, tenant in partnership, joint tenant, or tenant by the entirety, of the whole or of a part of such building or land.

Project Compliance Analyst (PCA) (DBNS): Staff member who provides project management through permit application, issuance, amendments/extensions, and closure. Coordinates with IPRs/RPRs to ensure project documentation is maintained, permit amendments are processed, and permits are closed once appropriate documentation is received.”.

Record Digital GIS Data: Attribute tables (.xslm) submitted per the digital standards representing the project as it was constructed in the field. This data shall be prepared per the most recent digital standards.

Record Digital Plan Data: Drawing files (.dwg or .dxf) of the Record Drawing Plans representing the project as it was constructed in the field. Drawing must include all applicable items from Storm Features and Miscellaneous Features.

Record Drawing (Digital Data Submission): Plans certified, signed, and dated by a professional engineer or land surveyor registered in the State of Indiana, indicating the Plans have been reviewed and revised, if necessary, to accurately show all as-built construction and installation details including, but not limited to, key elevations, locations, and distances. Record Drawings shall be in compliance with the Digital Data Submission Standards (DDSS) and be inclusive of all submittal requirements within the DDSS and will include Red-Line Record Plans, O&M Manual(s), Recorded Grant of Easement and/or Right of Way, including instrument number, Record Digital GIS Data, Record Digital Plan Data, and Record Reproducible Plans.

Record Reproducible Plans: PDF file copy of final plans corrected to represent the project as it was constructed in the field.

Red-Line Record Plans: Electronically created record drawing within a CAD platform containing comments and dimensions from the contract Resident Project Representative (RPR) for Public Projects or Contractor or Developer in consultation with the contract Inspecting Project Representative (IPR) for Private Projects. Red-Line Record Plans shall be PDF files created from CAD software “flattened” to protect the document from any possible revisions.

Resident Project Representative (RPR) (Public Project): The authorized representative from a Construction Inspection Firm who represent DPW for the City and is assigned to the site or any part thereof.

ROW: Right-of-Way

Substantial Completion (for Public Projects): The stage of construction where all pay items shall be completely installed, and all necessary testing as required by the Laws and Regulations and/or Contract Documents shall be completed. Substantial Completion may be evidenced by a certificate thereof issued by the RPR and signed by the OWNER.

Technical Review Consultant: Firm contracted in the Professional Services Agreement (PSA) with the City for the technical plan review of public and private projects.

III. Captured Assets and Features

Buildings: New and existing vertical structure footprints

Easements: The legal granted right of the City to cross or otherwise use private land, which may include utility, legal drain, drainage, right-of-way, etc.

Edge of Pavement: Edge lines used to outline and separate the outside edges of paved or unpaved streets, parking, sidewalks, trails, etc.

Flood Works: Levees, flood walls, dams, and associated storm features.

Signage: Signs included are traffic, pedestrian, warning, informative, and regulatory.

Signals: Signals included are traffic control, rail, and pedestrian.

Storm Mains: Features of the storm sewer system represented by a polyline such as pipes, culverts, ditches, hybrid ditches, etc.

Storm Structures: Features of the storm sewer system represented by a point such as manholes, inlets, wet/dry wells, etc.

Stormwater Quantity/Quality Features: Post-Construction BMP of the storm sewer system which treat storm water runoff for water quality and/or quantity such as detention ponds, mechanical BMPs, forebays, rain gardens, underground detention, etc.

Streetlights: City of Indianapolis DPW owned streetlights, included are general, safety, and decorative.

IV. Public Projects (DPW Capital Improvements): Digital Data Submission Process

For public projects, Construction Contractors' responsibilities can be found in the General Conditions of their contract documents, and the Design Consultant's and RPR's responsibilities can be found in Attachment A of their Contract Agreement.

A. Final Construction Plans to Record Drawing Submittal: (Design Consultant)

At Final Completion date, maximum of 45 days after the last date of the work by the Contractor, the verified and stamped Red-Line Record Drawings are to be placed in the Final Construction Record (FCR) folder by the RPR and submitted to the DPW Construction Project Manager and the DPW Design Consultant. The DPW Design Consultant will use the

Red-Line Record Plans to generate Record Reproducible Plans, Record Digital Plan Data and Record Digital GIS Data containing the following items:

1. All Storm Features (section VII-D-2) that are applicable. All drainage infrastructure locations and inverts shall be field verified by a professionally licensed surveyor. This information shall be provided by the Contractor at survey grade accuracy.
2. Signal and Streetlight locations must be acknowledged.
3. All Miscellaneous Features (section VII-D-6) that are applicable. All Record Drawing information provided for Miscellaneous Features shall be spatially verified with a minimum of mapping grade GPS, sub-meter or better.

B. Public Project submission process to DPW: (DPW Design Consultant)

1. Within 45 days of Final Completion, the DPW Design Consultant shall submit Red-Line plan in electronic format, per Attachment 'A' of the Professional Service Agreement (PSA), to the DPW Design Project Manager and email a digital file to the GIS Data Support Staff at DigitalData@indy.gov. Data shall be formatted as outlined in Section VI: Contents of the Digital Data Submission.
2. Files must adhere to the requirements as detailed in this document, including in Section VII below.
3. Submittals must be checked and accepted by the GIS Data Support Staff prior to project closeout.

C. Receiving Record Drawing Digital Submittals: (DPW Construction Project Manager)

The DPW Construction Project Manager ensures all Record Drawing Submittals, including appropriately completed checklists, are received, and meet the requirements as detailed in this document. The DPW Construction Project Manager reviews and relays to the GIS Data Support Staff whether they “Approve” or “Reject” the submission. If any of the submittals are found to be “Rejected”, the submittal with comments will be returned to the Design Consultant by the GIS Data Support Staff.

D. Reviewing and Retaining Record Drawing Digital Submittals: (GIS Data Support Staff)

1. Once the DPW GIS Data Support Staff receives confirmation from the DPW Construction Project Manager that the Record Drawing Digital Submittal is approved, GIS Data Support Staff will log it into the system and check for usability and compliance with the Digital Data Submission Standards.
2. If any of the submittals are found to be “Rejected”, the submittal, with comments, will be returned to the DPW Construction Project Manager as well as the DPW Design

Consultant. The GIS Data Support Staff will return the submittal to the DPW Design Consultant for revision/correction and the DPW Design Consultant must re-submit until the submittal is “Accepted”.

V. Private Projects: Digital Data Submission Process

A. Drainage Permit Requirements (Developer)

1. At the completion of the project, the Developer will coordinate with the Inspecting Project Representative (IPR) assigned by DBNS to get final inspections of the project. The Developer will then submit all required elements of the Digital Data submittal, including electronic versions of Record Reproducible Plans, Record Digital Plan Data and Record Digital GIS Data, to the Inspecting Project Representative (IPR) for review as part of the closure requirements for the drainage permit. A complete list of required documentation can be found in the DDSS Checklist, available from the IPR or DBNS Project Compliance Analyst (PCA) upon request. The submittal must contain the following data:
 - a. All storm features that are applicable, see Section VII-D-2. All drainage infrastructure locations and inverts shall be field verified by a professionally licensed surveyor. This information shall be provided at survey grade accuracy.
 - b. Signal and Streetlight locations must be acknowledged.
 - c. All Miscellaneous Features (section VII-D-6) that are applicable. All Record Drawing information provided for Miscellaneous Features shall be spatially verified with a minimum of mapping grade GPS, sub-meter or better.
2. The IPR will review and email the Developer to request revisions or email the submittal to the Digital Data team for approval and subsequently to DBNS for processing.
3. Additional closure documentation may be required as communicated by the IPR and/or PCA, or as outlined in the permit approval letter.

B. Private Development submission process to DBNS: (Developer and Inspecting Project Representative)

Files provided by the developer to the IPR must adhere to the requirements as detailed in this document, including Section VII for Private Projects.

The IPR will coordinate review of the Digital Data submission to the Digital Data team and include the PCA on that communication. Once the Digital Data team has approved the submittal, the IPR and PCA will coordinate on any other required documentation necessary to close the drainage permit.

C. Receiving Record Drawing Digital Submittals: (DBNS IPR)

DBNS, Project Compliance Analyst (PCA), and Inspecting Project Representative (IPR) will provide the Digital Data submission to GIS Data Support Staff at DPW by emailing DigitalData@indy.gov.

VI. Contents of the Digital Data Submission

The Digital Data Submission is the complete Record Drawing, which includes the Record Digital GIS Data, the Record Digital Plan Data, and the Record Reproducible Plans. Record Drawing submittal is required if a project adds new, alters existing, or removes existing easement, property ROW, or infrastructure (stormwater, pavement, building footprint, and/or DPW owned: signage, streetlights, fiber optic lines, buried traffic lines, and/or irrigation lines). The Record Drawing will be transmitted by an electronic submission (FTP site link or other Project Manager approved cloud file sharing).

The electronically shared files folder should be properly named with the following information:

- DPW Public Projects
 - Record Drawing_City Project Number_Month.Day.Year
 - **Example:** Record Drawing_SD-25-009_02.03.2018
- Private Projects
 - Record Drawing_Drainage Permit Number_Month.Day.Year
 - **Example:** Record Drawing_DRN18-00000_03.08.2018
- Each plan set shall cross-reference the DBNS permit number. For example: if they are stormwater as-builts, the drainage permit number DRN-XX-XXX should be included; if they are street as-builts, the street permit number STC-XX-XXX should be included.

VII. Record Drawing Submittal File Requirements

Media must be emailed to DigitalData@indy.gov and contain the following items:

A. Submittal Items: Final Construction Plans to Record Drawing Submittal

Submit items from list below.

- Record Reproducible Plans - pdf format (Re-printable at full scale, compiled into a single file less than 100MB in size if possible)
- Record Digital Plan Data - .dwg or .dxf format
- Record Digital GIS Data - .xlsm
- Red-Line Record Plans - .pdf format
- Operation & Maintenance (O&M) Manual(s) - .pdf format

- Recorded Grant of Easement and/or Right of Way, including instrument number

B. Submittal Reference Materials and Resources

The Project Design Consultant or Developer should refer to the latest available versions of the following documents on the City’s website (<https://www.indy.gov/activity/public-works-specifications-and-manuals>):

- The latest revisions of:
 - *Roadway and Bridge Specifications and Manuals*
 - *Stormwater Design and Construction Specifications Manual*
 - *Digital Data Submission Standards*
 - An Excel file, *GIS Digital Data Submission Standards – Attribute Tables: Storm Structures; Storm Mains; Traffic Signals; and Street Lights*, are to be used for the entry of attribute information shown in Appendix A.
 - *Sample CAD* (pdf. & .dwg) for Easement and GIS Submission drawing.
 - GIS Submission Checklist
 - Other relevant reference files as deemed necessary.

All projects shall acknowledge the IndyGIS copyright by stating “Source data provided by IndyGIS”, “Design by _____”

C. Record Reproducible Plan Requirements (.pdf)

Record Reproducible Plans are required with each Digital Data submittal. Submittals are to include all sheets of the modified plans from the original conformed set showing the new construction, deletion or alteration of existing infrastructure and its related properties.

1. Record Reproducible Plan Details

When adjusting plans to reflect the project as it was constructed in the field, the original design is to be left intact and changes to actual construction information is to be marked up digitally as cross-outs and/or revision clouds (all in RED).

Where a change is made to the final tracings, a revision note shall be placed in the revision block on the index sheet. This revision note shall include the date of the revision, the revised sheet numbers, and a short explanation of the change. A note with the same information shall also be placed on the revised sheet or sheets in a location that will not restrict its visibility.

No deletions may be made to the original tracings as they are considered a legal contract document at the time of letting. If space allows the original item to be revised should be hatch-marked through and the revision should be made on the same sheet. The revision shall be placed on the sheet in a location that will not restrict visibility and shown in a cloud. If the revision is too large to be shown on the original sheet, the deleted sheet

number shall be noted in the revision block. This deleted sheet remains in the original set of plans.

- Replacing an existing plan sheet. If an existing plan sheet is to be replaced, the replacement sheet shall be numbered with an alphabetic extension (number-letter) to indicate that it is a replacement sheet. The deleted sheet shall be identified in the revision block and remains in the original plan set for future reference. Clouds shall be used on the replacement sheet to indicate the changes made. The replacement sheet number shall also be identified in the revision block on the index sheet. Examples of the number-letter extension are as follows.
 - Sheet 2 is deleted, and Sheet 2-A will take its place.
 - Sheet 23 is deleted, and Sheet 23-A will take its place.
 - Sheet 17-A is deleted, and Sheet 17-B will take its place.
 - Sheet 15-1 is deleted, and Sheet 15-1-A will take its place. The number followed by a letter indicates that an existing sheet has been replaced.

- Inserting a new plan sheet. If a new sheet is to be inserted into the original plans, the added sheet shall be given a numeric extension, number-number, to indicate that it is an added sheet. A new sheet is numbered according to the sheet preceding the insertion. The added sheet shall be identified in the revision block on the index sheet. Clouds are not required around the periphery of the new sheet. Examples of the number-number extension are as follows:
 - Sheet 15-3 is inserted after Sheet 15-2 and before Sheet 16.
 - Sheet 7-1 is inserted after 7-B and before Sheet 8.
 - Sheet 40-3 is inserted after 40-2 at the end of the set of plans.
 - Sheet 5 is revised, and two new sheets are added. The sheet numbers are 5A, the revision to Sheet 5, 5-1, and 5-2, the two new sheets.

The markups shall be clear and legible. It is not acceptable to adjust the plans by hand. The Record Reproducible Plans shall be printed from the drafting/drawing software directly to PDF; scanned documents will not be accepted or considered as formal submissions. The Project Design Consultant (DPW Public Projects) or Developer (Private Projects) shall verify the record drawings accurately portray information as it was built in the field. If plan markups were verified by construction personnel, the Project Design Consultant may add a note on the plans stating as such. If existing infrastructure impacted during construction is returned to its original condition, these features need not be included as a part of the Digital GIS Data. All plans must be submitted as to scale, full size drawings, which is nominally 22" x 34" in size.

Note: Operations and Maintenance Manuals, (O&M Manuals) shall also be updated to reflect the project as it was constructed in the field and must be included in record drawing submittals for all stormwater quality or quantity features.

2. Record Reproducible Plan Summary:

- The file must be a multipage, single file .pdf with all pages orientated in the same direction. All sheets from as-bid or permit drawings must be included.
- All modifications must be clearly marked, legible, and in RED.
- For public projects, the file name must be the City project number followed by “Record Drawing”.
- For private development, the file name must be the drainage permit number followed by “Record Drawing”.
- The order of pages must match the index included in the plan set.
- Record Drawing plan sets must include a stamp on the cover that contains the following information:
 - Certification by engineer of record
 - Name of company submitting the Record Drawings
 - Creation date of the Record Drawing

D. Record Digital GIS Data Requirements (.dwg or .dxf)

A digital GIS file of all constructed/modified features is required. The Record Drawing GIS Data drawing shall include corrected locations of designed features, connections to existing features, required annotation, and other pertinent information regarding final constructed locations. Requirements for this file are as follows:

1. General

- a. All accompanying geodetic control shall be placed into one CAD file for new, altered and existing features not currently in the City GIS. The features in drawing files will be translated to real world locations. The geodetic control chosen must correspond to the existing features from Indy DPW (State Plane East projection, NAD 1983 State Plane Indiana East, US Feet).
- b. Features shall be submitted on the specified layer and each layer should be named according to the table in *Appendix A: Graphic File Features Specifications*. CAD systems which use a numbering system for layers instead of names shall also include a conversion chart explaining which layer number corresponds to the appropriate GIS layer name.
- c. Altered existing features shall use a different color than the new/improved infrastructure. It is at the discretion of the submitting firm as to colors.
- d. Only layers that contain data shall be included in the submission.
- e. Structures and the endpoints of lines shall be input as points or nodes only.

- f. The design ID (DGSN_ID) should be visible on the drawing in a standard font and the lower left-hand corner of the text should touch the point or linear graphic feature to which it corresponds, unless legibility requires that the label be moved and accompanied by a leader arrow.
- g. **Do not** use AutoCAD “leaders” as these are not visible to GIS. Instead, use a simple line on a separate layer apart from those used by IndyGIS.
- h. **Do not** use third-party symbols or line types in the .dwg or .dxf drawings as these will not be visible by City staff when opening the drawings.
- i. Miscellaneous features and text (except DGSN_ID) shall be placed on separate layers, apart from those used by IndyGIS.

2. Storm Features:

- a. All drainage infrastructure locations and inverts shall be field verified by a professionally licensed surveyor. This information shall be provided at survey grade accuracy.
- b. All storm lines and ditches are to be entered as a single line between structures. Double lines or a continuous polyline running through structures are not acceptable unless it’s representing a hybrid ditch. Each storm section between structures must be a separate single line segment. Polylines are allowed only where turns in the line do not have structures present, i.e., ditch in a curved path.
- c. All storm lines must be digitized in the direction of their physical flow. The beginning point of the line shall be its upstream end and the ending point shall be its downstream end.
- d. All lateral storm lines shall be drawn from the right-of-way perpendicular to the storm main. End point of lateral shall snap to the main collector linework.
- e. The end points of all storm lines shall be snapped to nodes.
- f. New or altered infrastructure features, such as manholes and runs of storm line are to each have a unique identifying number (Design Identification, DSGN_ID) shown in the drawing. For existing infrastructure use IndyGIS established UNITID (Asset Identification – IndyGIS assigned) for those structures. Ownership between public and private shall be differentiated.
- g. It is required that a single segment (the portion of sewer line between two structures) of sewer have the exact same DSGN_ID as its upstream structure.

3. Traffic Features – TBD

4. Streetlighting Features - TBD

5. Fiber/Communication Features - TBD

6. Miscellaneous Features:

- a. DPW owned Easements (Storm, Legal Drain, Traffic, Fiber optic, Streetlight, Irrigation, Cultural Trail, etc.) shall be shown as polylines and labeled with text that identifies the: Owner, Instrument Number, and Type of Easement, see example Easements AutoCAD file at the [Specifications & Manuals](https://www.indy.gov/activity/public-works-specifications-and-manuals) website (<https://www.indy.gov/activity/public-works-specifications-and-manuals>).
- b. Property Lines shall be shown as polylines.
- c. Right-Of-Way shall be shown as polylines.
- d. Building Footprints shall be shown as polylines.
- e. Pavements shall be shown as polylines.
- f. DPW owned Signage shall be show as a node.
- g. DPW owned Signals shall be shown as a node.
- h. DPW owned Streetlights shall be shown as a node.
- i. DPW owned Fiber Optic Lines shall be shown as polylines.
- j. DPW owned Overhead and Buried Traffic Lines shall be shown as polylines.
- k. DPW owned Irrigation Lines shall be shown as polylines.

Note: Existing storm facilities found on site/in the field may not be present within provided IndyGIS data and should be identified and noted as such when submitting the Digital GIS Data drawing by inserting text or a callout on a layer apart from those used by IndyGIS. Ownership between public and private shall be differentiated.

E. Record Digital GIS Data Requirements (.xlsm)

Many of the City GIS features have useful descriptive attributes stored in databases. These attributes are derived from the submitted plans. The submitting Design Consultant (Public Projects) or Developer (Private Projects) will be provided an approved Excel format worksheet on the DPW website [Specifications & Manuals](https://www.indy.gov/activity/public-works-specifications-and-manuals) (<https://www.indy.gov/activity/public-works-specifications-and-manuals>), under the heading **General Specifications and Manuals**. These tables contain all fields and validated data which are required by the City regarding new or modified assets. The files have been developed with domains/drop downs to promote more consistent field population.

Each record in the file shall be assigned a unique Design ID (DSGN_ID), which will correspond to text labels in the CAD file showing the referenced feature. The unique numbers for each feature shall be listed within the DSGN_ID column of the spreadsheet, with the corresponding attribute columns for each feature. This will allow the GIS Data Support Person to sort and import this data into GIS and assign them to appropriate features imported from the submitted design file. All attributes are required for new or modified features.

The Excel file shall be returned in the same file format as provided, and any modifications to the table structure and/or format shall result in an immediate rejection of the submission. The file contains tabs for each asset category (Storm Structures, Storm Mains, Traffic Signals, Streetlights, Fiber, Irrigation, Dams, and Levees) along with an additional tab (Field Descriptions) which describes each of the field names and contents. In the Field Descriptions tab, all attribute fields with a 'YES' flag under the 'Required' column must be populated with the appropriate data for the City GIS Project Manager to accept the entire drawing. Diagrams for Storm Mains fields MAINS_SHAPE, PIPE_WIDTH, and PIPE_HEIGHT along with a more complete definition for NPDES_OUTFALL from the *Storm Structures*' attribute table is found below in Appendix C.

Appendix A: Graphic File Features

FEATURE	LAYER	TYPE
Ditches (Ditch, Hybrid Ditch)	DITCHES	LINestring
Storm Mains (Culvert Pipe, Box Culvert, Perforated Pipe, Pipe System, Slotted Main)	STORMLIN	LINestring
General Annotation	General_ANNO	TEXT
Storm Main Abandoned	STORMLIN_ABAN	LINestring
Storm BMP Linestrings (Water Quality Swale, In-Line Detention Pipe)	STORMBMP	LINestring
Channel (Concrete Channel, Main Channel)	CHANNEL	LINestring
Storm Structures (Storm Manholes, Inlets, Outfalls, Nodes, etc.)	STORMSTR	POINT
Storm BMP Points (Hydrodynamic separator, detention pond, forebay, underground detention, green roof, permeable pavement, water quality swale, In-Line Detention Pipe, etc.)	STORMBMP	POINT
Storm BMP Polygons (Permeable pavers)	StormBMP	POLYGON
Storm Pump Station	STORMLIFTSTATION	POINT
Rip Rap - Stone	RIP_RAP	LINestring
Legal Drain Easement	LDESMT	LINestring
Legal Drain Center Line	LEGAL_DRAIN	LINestring
DPW Easements	DPWESMT	LINestring
Right-of-Way	RGTOFWAY	LINestring
Property Lines	PROPLINE	LINestring
Building Footprint	BUILDING	POLYGON
Pavements	PAVEMENT	LINestring
DPW Signage	SIGNAGE	POINT
DPW Traffic Signal Heads	SIGHEAD	POINT
DPW Streetlight	STREETLIGHT	POINT
DPW Fiber Optic Line	FO_LINE	LINestring
DPW Buried Traffic Line	TRAFFIC_BURIED	LINestring
DPW Overhead Traffic Line	TRAFFIC_OVERHEAD	LINestring
DPW Irrigation Lines	IRRIGATION_LINE	LINestring
Centerlines	CNTRLIN	LINestring
Geodetic Control	CONTROL	POINT
Curbs	CURB	LINestring
Lift Stations	LIFTSTAT	POINT
Parking	PARKING	LINestring
Sidewalk	SIDEWALK	LINestring

Sidewalk Ramps	ADARAMPS	POINT
Unpaved Roads	UNPAVED	LINestring
Parcels	PARCELS	POLYGON
Signal Controller Cabinets	SIGCOCAB	POINT
Streams	STREAMS	LINestring
Traffic Signal Poles	SIGPOLE	POINT
Signal Mast Arms/Span Guys	SIGSPAN	POINT
Signal Access Holes	SIGHOLE	POINT
Walls (flood walls, guard rails, bridge-headwalls, retaining walls, etc.)	WALLS	LINestring & Node
Levees	LEVEES	POLYGON
Levee Nodes	LEVEENODES	POINT
Lines delineating Subdivision Only	S	LINestring
Subdivision Name	SUB_NAM	TEXT
Landhooks	LHOOK	LINestring
Address Number	ADD_TXT	TEXT
Lot Numbers	LOT_NO	TEXT
Block Numbers	BLOCK_NO	TEXT
Lot Dimension	LOT_DIM	TEXT
Miscellaneous Lines	MISC	LINestring
Miscellaneous Text	MISC	TEXT
Dams	DAMS	POLYGON
Fiber (ISA)	XXX	LINestring

Appendix B: DDSS Submission Checklist

Digital version of the *DDSS Checklist* can be found at: [Specifications & Manuals](https://www.indy.gov/activity/public-works-specifications-and-manuals)
 (<https://www.indy.gov/activity/public-works-specifications-and-manuals>)



Digital Data Submission Checklist

Company Name: Date:

Submitter Name:

Project/Drainage Number:

Project Name:

City's Reviewer	Submitter	
1 <input type="checkbox"/>	<input type="checkbox"/> Yes <input type="checkbox"/> N/A	Was the file named correctly? For Public Projects, the file name must be the City project number followed by "Record Drawing." For Private development, the file name must be the drainage permit number followed by "Record Drawing"
Comments: <input type="text"/>		
2 <input type="checkbox"/>	<input type="checkbox"/> Yes <input type="checkbox"/> N/A	Do the plans include a stamp on the cover containing: Record Drawing stamp, the name of the company submitting the Record Drawings, and the creation date of the Record Drawings?
Comments: <input type="text"/>		
3 <input type="checkbox"/>	<input type="checkbox"/> Yes <input type="checkbox"/> N/A	Was the plan submitted as to scale, full size drawings, nominally 22" x 34" in size?
Comments: <input type="text"/>		
4 <input type="checkbox"/>	<input type="checkbox"/> Yes <input type="checkbox"/> N/A	Were the record drawings printed directly to PDF from the drawing software as a multipage, single file .pdf with all pages orientated in the same direction. All sheets from as-bid or permit drawings must be included.
Comments: <input type="text"/>		
5 <input type="checkbox"/>	<input type="checkbox"/> Yes <input type="checkbox"/> N/A	Did the Design Consultant (Public Projects) or Developer (Private Projects) verify that the record drawings accurately portray information as it was built in the field.
Comments: <input type="text"/>		
6 <input type="checkbox"/>	<input type="checkbox"/> Yes <input type="checkbox"/> N/A	Were Operations and Maintenance (O&M) manuals included for all stormwater quality and quantity features?
Comments: <input type="text"/>		
7 <input type="checkbox"/>	<input type="checkbox"/> Yes <input type="checkbox"/> N/A	Is the data in State Plane East projection, NAD 1983 State Plane Indiana East, US Feet?
Comments: <input type="text"/>		
8 <input type="checkbox"/>	<input type="checkbox"/> Yes <input type="checkbox"/> N/A	Is the drawing format in AutoCAD (.dwg) or Universal Drawing (.dxf)?
Comments: <input type="text"/>		
9 <input type="checkbox"/>	<input type="checkbox"/> Yes <input type="checkbox"/> N/A	Red-Line Record Plans: Was the original design left intact and changes to actual construction information marked up digitally (all in red)?
Comments: <input type="text"/>		

Digital Data Submission Checklist

10	<input type="checkbox"/> Yes <input type="checkbox"/> N/A	Are all new, altered, or removed asset elements represented and correctly annotated?	
Comments:			
11	<input type="checkbox"/> Yes <input type="checkbox"/> N/A	Are all elements placed on the correct layer of the CAD drawing? See Appendix A of the Digital Data Submissions Standards.	
Comments:			
12	<input type="checkbox"/> Yes <input type="checkbox"/> N/A	Are storm mains digitized as a single-line, individual entity, for each sewer segment between structures on the layer "STORMLIN"?	
Comments:			
13	<input type="checkbox"/> Yes <input type="checkbox"/> N/A	Are storm mains digitized in the same direction as their physical flow (from upstream to downstream) and labeled with the upstream stream structure number?	
Comments:			
14	<input type="checkbox"/> Yes <input type="checkbox"/> N/A	Are storm line end points snapped together?	
Comments:			
15	<input type="checkbox"/> Yes <input type="checkbox"/> N/A	Are storm structure/nodes digitized as point features, on the layer "STORMSTR"?	
Comments:			
16	<input type="checkbox"/> Yes <input type="checkbox"/> N/A	Are storm structure points snapped to the sewer main endpoints?	
Comments:			
17	<input type="checkbox"/> Yes <input type="checkbox"/> N/A	Are storm lines and structures labeled with DSGN_ID (Design ID) numbering scheme?	
Comments:			
18	<input type="checkbox"/> Yes <input type="checkbox"/> N/A	Are Dams and/or Levees digitized as polygons?	
Comments:			
19	<input type="checkbox"/> Yes <input type="checkbox"/> N/A	Are storm main DSGN_IDs exactly the same as their corresponding upstream structure DSGN_IDs?	
Comments:			
20	<input type="checkbox"/> Yes <input type="checkbox"/> N/A	Is DSGN_ID text placed on the same layer as its respective features.	
Comments:			
21	<input type="checkbox"/> Yes <input type="checkbox"/> N/A	Do DSGN_ID numbers shown in CAD drawing match DSGN_ID numbers entered in the attribute data tables and PDF plans?	
Comments:			

Digital Data Submission Checklist

22	<input type="checkbox"/> Yes <input type="checkbox"/> N/A	<p>Are ordinary lines for other entities, such as leaders and notes, placed on a non-GIS layer? Do not use AutoCAD annotative dimension leaders are "invisible" to GIS and cannot be seen. Instead, use a simple line on a separate layer apart from those used by IndyGIS</p> <p>Comments: _____</p>
23	<input type="checkbox"/> Yes <input type="checkbox"/> N/A	<p>Are all Right-of-Way (ROW) and property lines and DPW owned easements shown as polylines and recorded in the correct layers (RGTOFWAY, DPWESMT, and PROPLINE respectively).</p> <p>Comments: _____</p>
24	<input type="checkbox"/> Yes <input type="checkbox"/> N/A	<p>Are all DPW owned easements (Storm, Traffic, Fiber optic, Street Light, Irrigation, and Cultural Trail) labeled with text that identifies the: Owner, Instrument Number, and Type of Easement, see example AutoCAD file at the website (https://www.indy.gov/activity/public-works-specifications-and-manuals).</p> <p>Comments: _____</p>
25	<input type="checkbox"/> Yes <input type="checkbox"/> N/A	<p>Is ownership between public and private infrastructure differentiated?</p> <p>Comments: _____</p>
26	<input type="checkbox"/> Yes <input type="checkbox"/> N/A	<p>Were attribute tables (https://www.indy.gov/activity/public-works-specifications-and-manuals) completed for Storm Mains and Storm Structures ?</p> <p>Comments: _____</p>
27	<input type="checkbox"/> Yes <input type="checkbox"/> N/A	<p>Did you avoid third-party symbols or linetypes in the .dwg or .dxf drawings? These will not be visible by City/County staff when opening the drawings.</p> <p>Comments: _____</p>

Submitter's Name: _____

Submitter's Signature: _____

City Reviewer's Name: _____

City Reviewer's Signature: _____

Appendix C: Attribute Table Definitions and Descriptions

D. Storm Structure Field

NPDES Outfalls

NPDES Outfall: Separate storm sewer outfall that is a 12-inch or larger pipe or 24-inch bottom width or larger ditch that outfalls to a water of the state.

Clarifications:

- NPDES Outfalls can be public or private
- NPDES Outfalls can be located in the Combined Sewer (CSO) area but must be separate storm sewers only.
- For this submittal, outfalls which are in another jurisdiction such as an excluded city or university (Southport, Speedway, Lawrence, Beech Grove, Cumberland, Tri-County Conservancy District, INDOT, Butler University, IU-Indianapolis, PU-Indianapolis, University of Indianapolis, Marian University) should be labeled as NPDES Outfalls.
- NPDES outfalls:
 - Included: Discharging to waters of the state (rivers, reservoirs, creeks, etc.)
 - Not included: Discharging to manmade waters such as detention ponds.

E. Storm Main Fields

Pipe Shape and Dimensions (PIPE_SHAPE, PIPE_WIDTH, AND PIPE_TYPE)

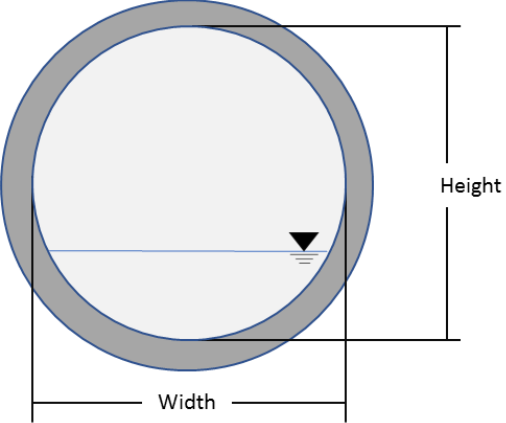
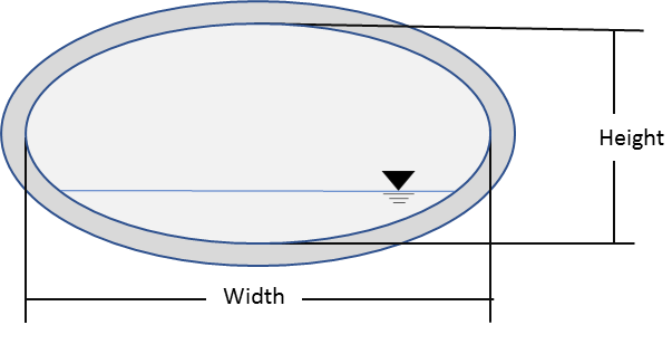
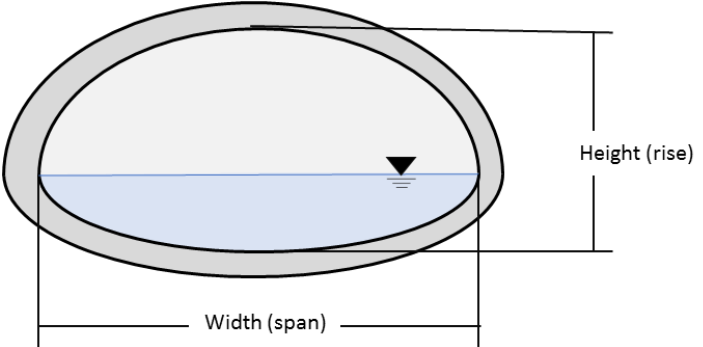
Circular	 <p>A diagram of a circular pipe cross-section. The pipe is shown as a thick gray ring. A horizontal blue line represents the water level, with a small inverted triangle and wavy lines below it. Dimension lines indicate the 'Width' (the diameter of the pipe) and the 'Height' (the vertical distance from the bottom of the pipe to the top of the water level).</p>
Elliptical	 <p>A diagram of an elliptical pipe cross-section. The pipe is shown as a thick gray ring. A horizontal blue line represents the water level, with a small inverted triangle and wavy lines below it. Dimension lines indicate the 'Width' (the major axis of the ellipse) and the 'Height' (the vertical distance from the bottom of the pipe to the top of the water level).</p>
Pipe-Arch	 <p>A diagram of a pipe-arch cross-section. The pipe is shown as a thick gray ring. A horizontal blue line represents the water level, with a small inverted triangle and wavy lines below it. Dimension lines indicate the 'Width (span)' (the horizontal distance between the two supports) and the 'Height (rise)' (the vertical distance from the bottom of the arch to the top of the water level).</p>

7.

Culvert Shapes and Dimensions

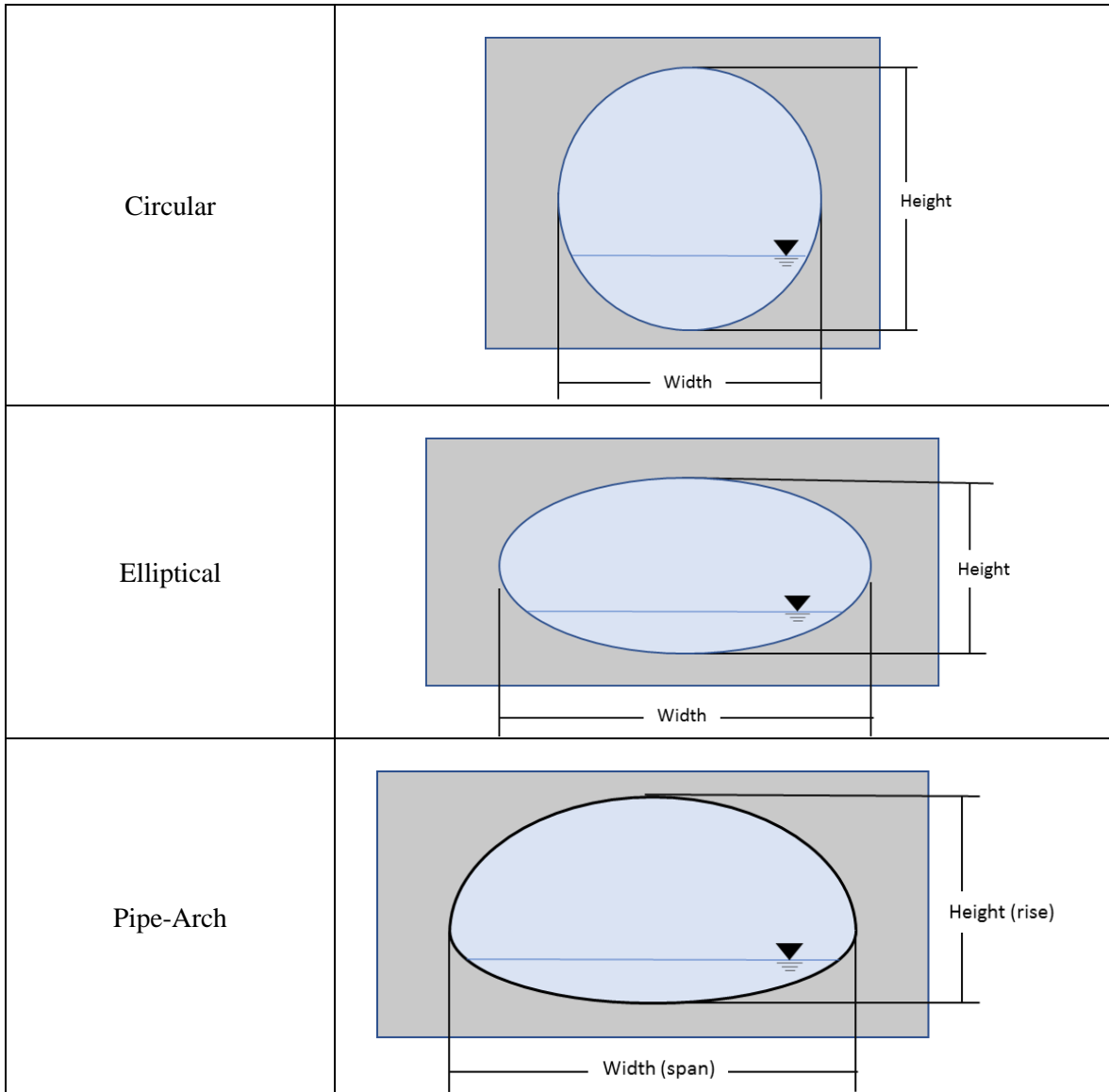

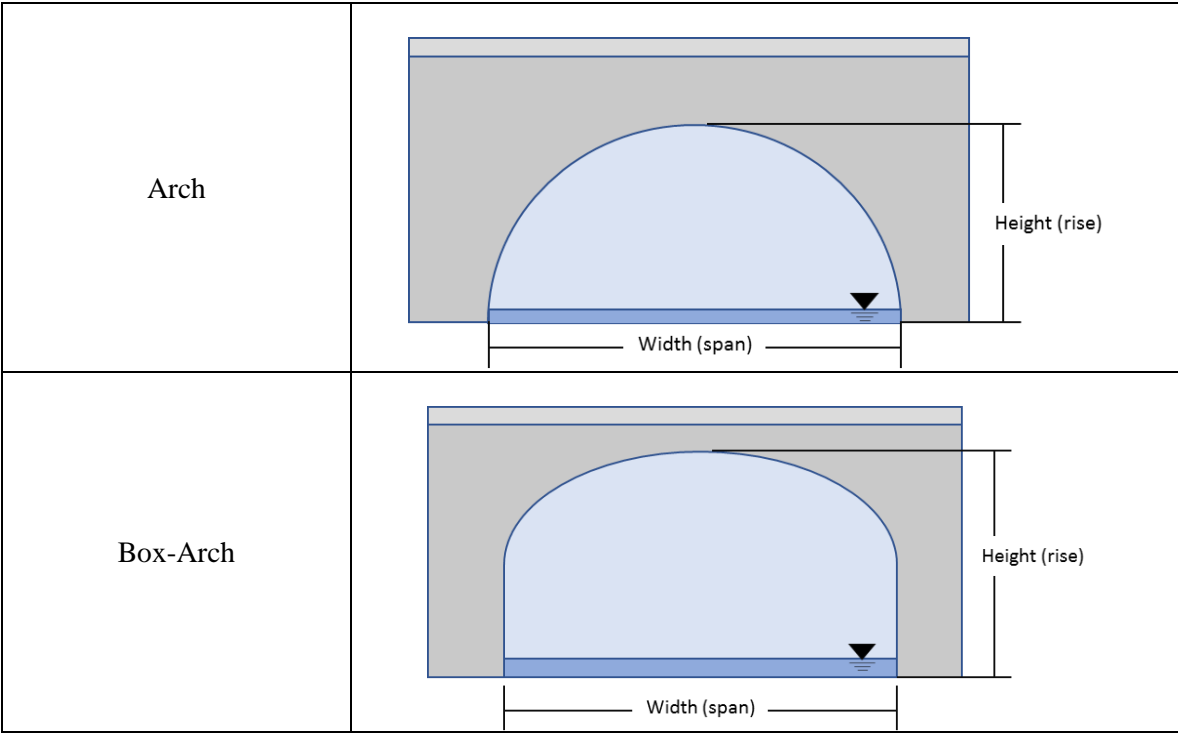

Channel Shapes and Dimensions

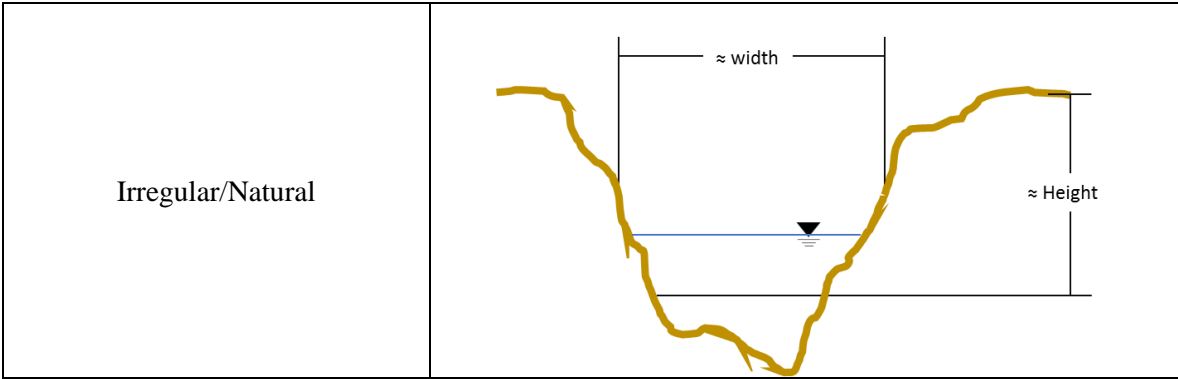

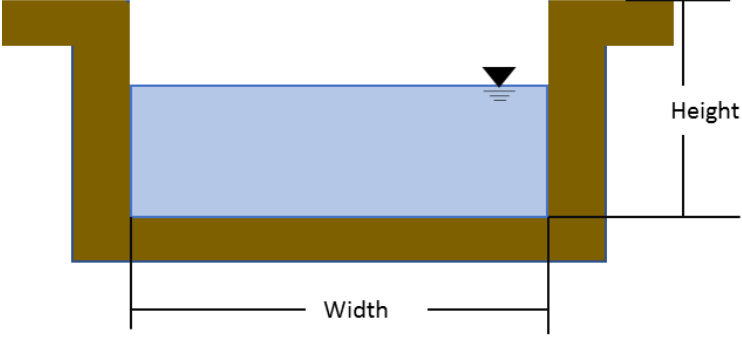
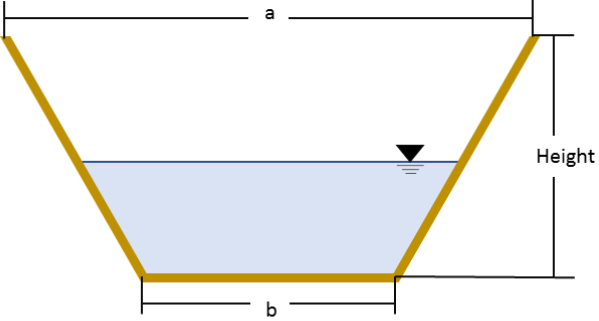
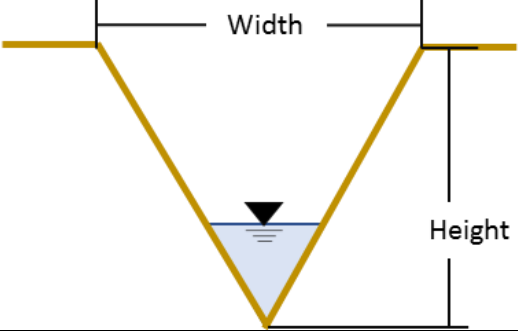
<p>Rectangular</p>	
<p>Trapezoid</p>	 $width = \frac{(a + b)}{2}$
<p>V-Shaped</p>	

Revision History

- ~~Revisions 7/6/98: Changed the names of storm and sanitary tables due to an upgrade of Hansen IMS. Changed attribute table format from xls to dbf to keep field structures.~~
- ~~Revisions 3/15/99: Added in labeling requirements for the data exchange media. Added in table information for sewer layers. Identified fields that must be populated with data.~~
- ~~Revisions 3/29/99: Added in required graphic specification for line input direction on page 2 within the first bullet.~~
- ~~Revisions 8/10/99: Added in missing table information for sewer layers that was left off from earlier revision to match the .dbfs. Changed the UNITID names where appropriate to match the .dbf headings.~~
- ~~Revisions 3/14/00: Changed all SUBAREA Field Types to read CHAR (3) instead of CHAR (4) and added appropriate wording to the description field. Changed the lookup table 038.dbf to 035.dbf in the description for FRAME TYPE on Storm and Sanitary Manhole sections.~~
- ~~Revisions 6/16/00: Added in new sub-bullet under 'Required graphic specifications...' bullet on page 2 describing how line segments should be input so that each node/structure constitutes an end of that line segment.~~
- ~~Revisions 8/16/00: Removed SEGID Field from the Compstmn.dbf, the Compsteh.dbf and the Compcmn.dbf tables. These descriptions did not match the actual tables and therefore are not needed. Added the IMS lookup table tbl084 to the NODETYPE field description for the Storm Node (Compstnd.dbf) section.~~
- ~~Revisions 12/22/00: Added missing lookup table tbl085.dbf for DWNCONN field under the Storm Inlet (Compstin.dbf) section to the IMS Lookup Tables and amended the description field accordingly on page 10.~~
- ~~Revisions 02/08/01: Added clarification information on page 3 under the second point concerning attribute information submitted in a database file. The second paragraph was added to state that we need all database files returned with the digital submission.~~
- ~~Revisions 02/19/01: Added more language to the same point as above and added the sub-title/instruction line on first page.~~
- ~~Revisions 08/21/01: Added example photos on pages 2 & 3 and changed text to match the layer & line types as shown in the picture. Added City name to Title.~~
- ~~Revisions 08/24/01: Added last bullet on page 4 describing existing sewer features not found in GIS data.~~
- ~~Revisions 09/24/01: Changed Figure 1 from an ArcView snapshot to an AutoCAD snapshot of the same data and area. Modified a few words in the description to match the new snapshot.~~
- ~~Revisions 04/07/08: Changed Contractor to Design consultant (contractor) where needed on page 4 and added information statement to AREA field in dbf table lists for help finding id numbers. Added 'overall project' to the section directly above Figure 2 and added information to the title of Figure 2.~~
- ~~Revisions 05/12/08: Added some clarifying language to the top paragraph of page 3 and Figure 2.~~
- ~~Revisions 12/21/10: Creation of version 2.1.1~~
- ~~Revisions 10/13/11: Added MHDPPTH as a required field for Compstmh.dbf table and added NODETYPE as a required field for Compstnd.dbf. Creation of version 2.1.2.~~
- ~~Revisions 11/28/11: Updated lookup tables tbl033 and tbl123. Creation of version 2.1.3.~~
- ~~Revisions 02/03/12: Edited label requirements for standard transfer media on page 5.~~
- ~~Revisions 03/10/14: Removed mention of tagged image file format; added additional details for PDFs on page 6. Creation of version 2.1.4.~~
- ~~Revisions 03/18/14: Added additional details for DWG requirements for As-Bid submittals under the Digital Plan Data Requirements on page 6.~~

- ~~Revisions 05/09/2019: Restructure and Reissue of Digital Submission Standards; revisions above are null and invalid. Creation of version 3.0.0~~
- ~~Revisions 07/10/2020: Clarifications and Reissue of Digital Submission Standards; revisions above are null and invalid. Creation of version 3.0.1~~
- ~~Revisions 09/29/2021: This update includes, but is not limited to grammatical edits, clarification that it is the responsibility of the contractor to supply survey grade locations and inverts for all newly added and/or altered stormwater features within the project boundaries, and changes to the allowable formats by which the digital submission may be transferred to the City of Indianapolis. Creation of version 3.0.02~~
- Revisions 9/30/2024 – Broke out public and private process.